

"Tube Temp" Knife Edge Thermocouples

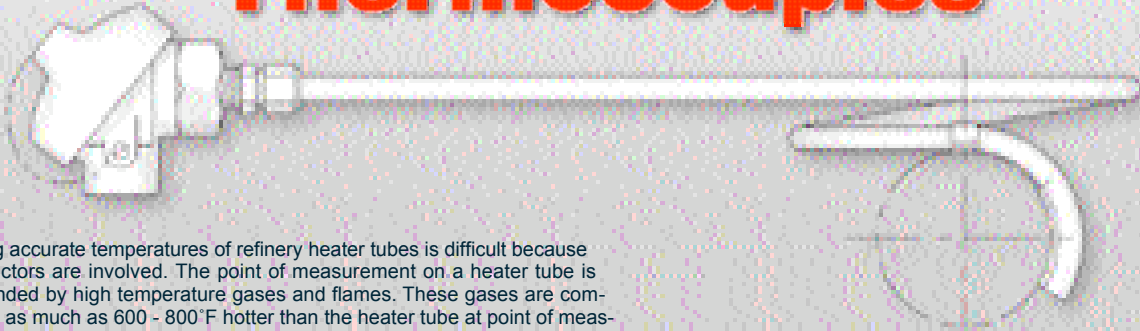

Obtaining accurate temperatures of refinery heater tubes is difficult because many factors are involved. The point of measurement on a heater tube is surrounded by high temperature gases and flames. These gases are commonly as much as 600 - 800°F hotter than the heater tube at point of measurement. The gases are also corrosive to thermocouple materials. Heat transfer along the length of the thermocouple assembly to its point of attachment on the heater tube tends to cause the thermocouple to be responsive to the higher gas temperatures rather than the desired tube wall temperature.

Many attempts to monitor tube wall temperature with accuracy and reliability have failed because either the attachment of the element to the tube was inadequate or the shielding to prevent direct flame impingement at the point of attachment was too extensive.

When the conventional "Pad" thermocouple is welded to a tube surface, a void space may occur between the underside of the pad and the tube surface. This void space impedes heat transfer from the pad to the cooler heater tube wall. The result is that heat energy from flame impingement and furnace gases flow to the pad edges and through the securing welds to the tube wall. This indirect flow path retards the absorption rate of the tube surface beneath the pad and the thermocouple is responsive to pad temperature which is considerably higher than tube wall temperature.

The "Tube Temp" thermocouple is designed to be responsive to tube wall temperature by placing the thermojunction in fused contact with the tube wall and by providing a direct and totally metallic heat transfer path from the sheath to the tube wall.

The "Tube Temp" thermocouple provides better accuracy, superior reliability, improved longevity and ease of installation over competitive thermocouples available for fired heater tube temperature measurement.

When you specify "Tube Temp" thermocouples, you are specifying an unsurpassed technology currently in use around the world. You will also receive unparalleled service and support from Thermo-Couple Products. With quality programs in place to meet and exceed the requirements of ISO 9001:2000, you can be sure that you are buying the best when you ask for Thermo-Couple Product's "Tube Temp" thermocouple.

"Tube-Temp" Thermocouple U.S. Patent Numbers
3,874,239 . . . 3,939,554 - 4,043,200
Canada Patent No. 1,012,258 - 1,016,666
Great Britain 1,478,919
Japan 1,043,379 - 1,070,744

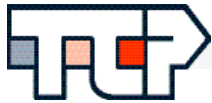

Thermo-Couple Products Co.

“TUBE TEMP” INSTALLATION DETAILS

Tube Temps

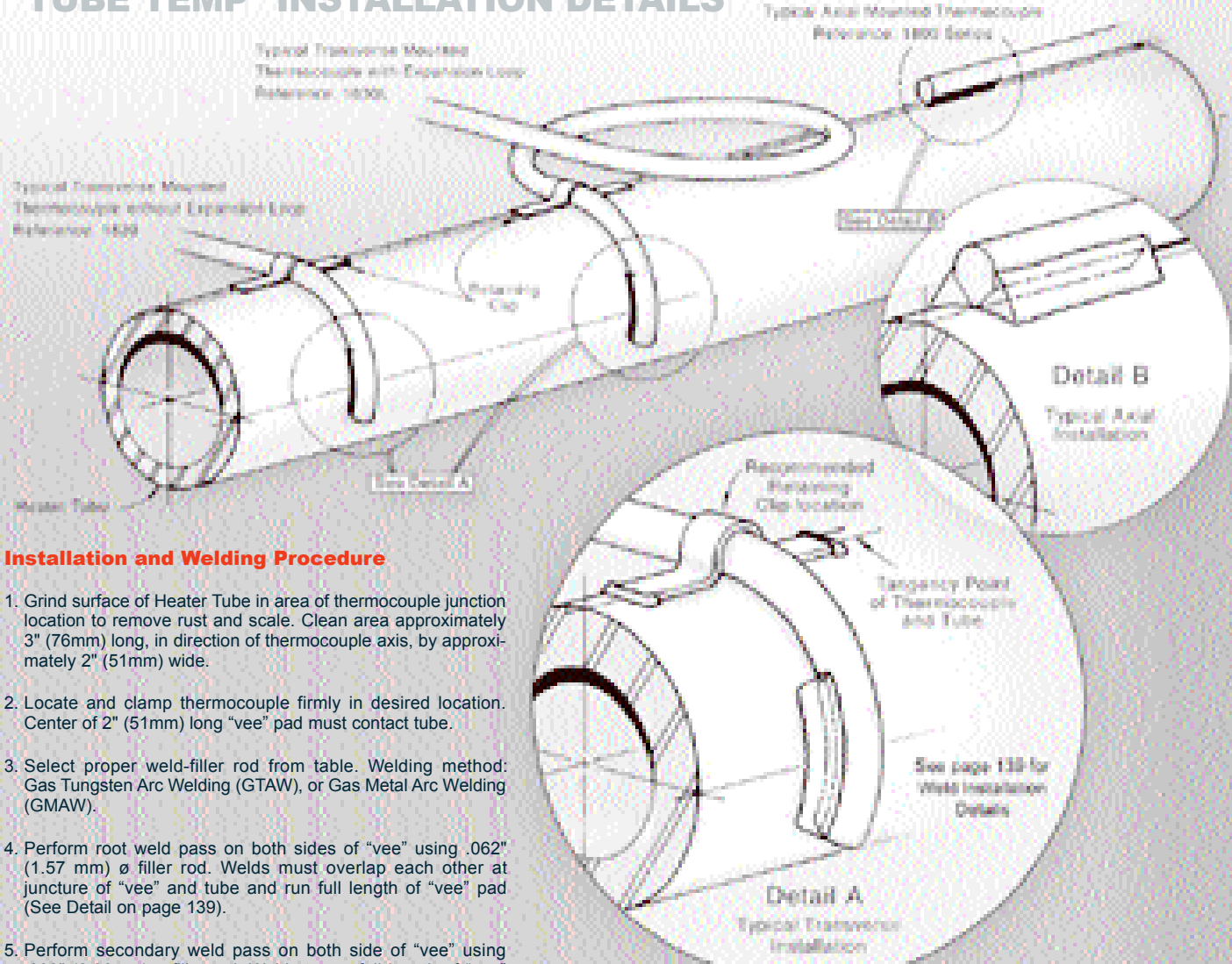

Installation and Welding Procedure

1. Grind surface of Heater Tube in area of thermocouple junction location to remove rust and scale. Clean area approximately 3" (76mm) long, in direction of thermocouple axis, by approximately 2" (51mm) wide.
2. Locate and clamp thermocouple firmly in desired location. Center of 2" (51mm) long "vee" pad must contact tube.
3. Select proper weld-filler rod from table. Welding method: Gas Tungsten Arc Welding (GTAW), or Gas Metal Arc Welding (GMAW).
4. Perform root weld pass on both sides of "vee" using .062" (1.57 mm) ϕ filler rod. Welds must overlap each other at juncture of "vee" and tube and run full length of "vee" pad (See Detail on page 139).
5. Perform secondary weld pass on both side of "vee" using .093" (2.36mm) ϕ filler rod. Welds to run full length of "vee" pad (See Detail on page 139).
6. Perform final weld passes on both side of "vee" using .093" (2.36mm) ϕ filler rod. Welds must extend .375" (9.5mm) minimum above tube surface and run full length of "vee" pad (See Detail on page 139).
7. Transverse mounted thermocouples: Locate Retaining Clip at tangency point of thermocouple and tube and weld at both ends only using .093" (2.36mm) ϕ filler rod. (See Detail "A" above.)
8. Axial mounted thermocouples: Locate Retaining Clip as desired and weld same as step 7.
9. Assemblies requiring on-site "field" forming or reforming to adjust fit must not be "cold" formed. Portions of thermocouple to be formed or reformed must be heated to 1400 to 1500°F (760 to 815°C) during forming operations. 2" (51mm) minimum bend radius recommended. Do not attempt to reform 2" (51mm) long "vee" pad containing junction.

Recommended Weld Filler Rod Materials: 446SS Sheathed "Tube-Temp" Assemblies	
Heater Tube Material	Filler Rod Material
ASTM A 312, TP 304, TP 309 OR TP 310	309SS-AWS A5.9, Class ER309
ASTM A 312, TP 321 (18% Cr, 10% Ni) Ti Stabilized	
ASTM A 312, TP 347 (18% Cr, 10% Ni) Cb Stabilized	
HK-40	Inconel 82 - AWS A5.14, Class ER Ni Cr 3
ASTM A 335, P 11 (1-1/4% Cr, 1/2% Mo)	
ASTM A 335, P 22 (2-1/4% Cr, 1% Mo)	
ASTM A 335, P 5 (5% Cr, 1/2% Mo)	
ASTM A 335, P 9 (9% Cr, 1% Mo)	
ASTM A 200, T 22 (2-1/4% Cr, 1% Mo)	
ASTM A 161, T 1 (.16% C max., .5% Mo)	
ASTM A 106 Carbon Steel	
INCOLOY 800	
410SS	

For recommended weld filler rod material when welding other than 446 SS sheath, please consult factory.

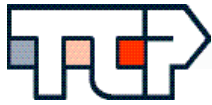

Thermo-Couple Products Co.

“TUBE TEMP” THERMOCOUPLES

- The most Accurate Measurement Device for Fired Heater and Industrial Boiler Tubes on the Market Today.
- Patented Knife-Edge Thermo-junction
- Factory Preformed designs Readily Available
- 446 Sulfur Resistant Stainless Steel Sheath. Also Available in 310 Series Stainless Steel and Hastelloy X. Other Materials Available Upon Request
- Three Year Reliable and Drift Free Life Under Normal Heater Use.

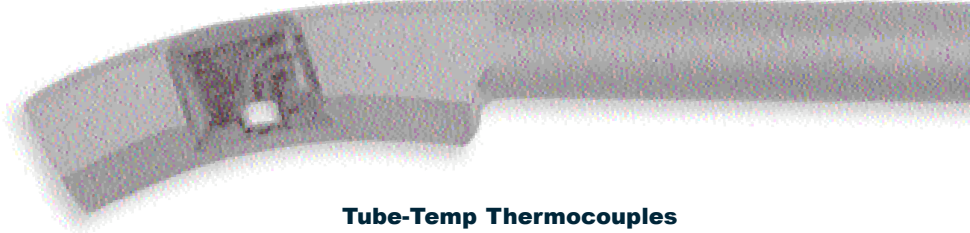

The “Tube Temp” is the Most Accurate Measurement Device for Fired Heater and Industrial Boiler Tubes on the Market Today

TCP’s “Tube Temp” thermocouples are ideal for the reliable measurement of tube wall temperatures in fired heaters which is important for prolonging tube life and ensuring safe and efficient operation. Accurate tube wall temperature measurement allows the operator to adjust operating conditions to limit tube wall temperatures below allowable limits while maximizing product flow.

The “Tube Temp” construction offers outstanding advantages for the temperature measurement:

- Long Drift-free usable life because combustion products are effectively isolated from contact with the thermocouple conductors.
- No special supports required within the heater fire box because of the inherent high temperature strength of the sheath materials.
- Thermocouple heads mount directly to the thermocouple element without the need for auxiliary support devices.
- Minimum radiant heat blockage “shadow effect” due to a small diameter when compared with pipe and insulator systems.

TCP’s “Tube Temp” thermocouple is one-half inch (.500”) diameter with a sheath wall thickness of nominal .120” (except Hastelloy material). The insulating material is highly compacted magnesium oxide and the conductors are nominal #14 B & S Gauge. A fused junction provides a direct, totally metallic heat transfer path from the tube wall to the sensor. Readings are unaffected by hot combustion gases.

Many standard configurations of the “Tube Temp” are available to fit your application. The following pages outline calibrations, lengths, junctions style, sheath material, wrap-around angles and other information necessary for selection appropriate “Tube Temp” model. “Tube Temp” thermocouples can be designed and factory formed to suit nearly any custom installation or application. Consult factory for custom applications.

“Tube Temp” Custom Designs are available

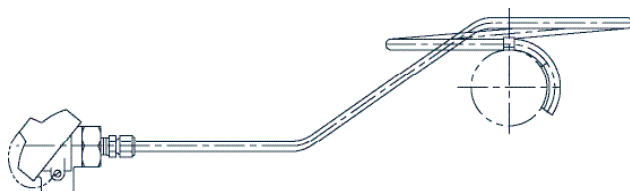

Tube-Temp Thermocouples

While the “Tube Temp” design has attracted many imitations, the Tube Temp’s patented “Knife-edge” thermojunction provides accurate readings unmatched by any competing product.

1800V Series
• See page 144

1800 Series
• See page 141

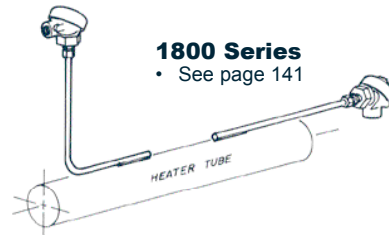

1800R Series
• See page 143

1800L Series
• See page 142

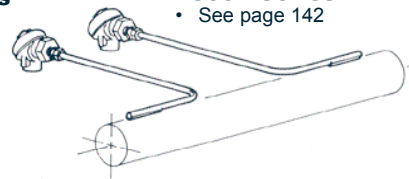

1810 Series
• See page 145

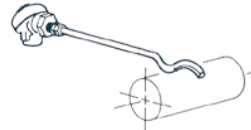

1820R Series
• See page 148

1820 Series
• See page 146

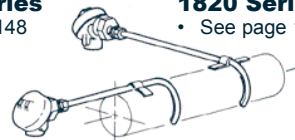

1820C Series
• See page 149

1820L Series
• See page 147

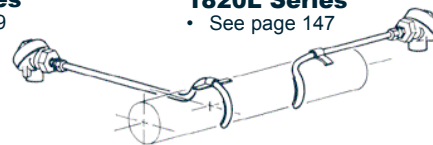

1830R Series
• See page 151

1830L Series
• See page 150

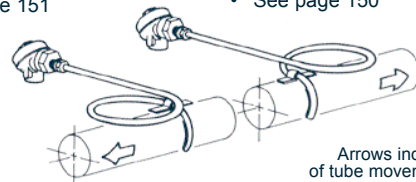

Arrows indicate direction of tube movement or growth due to heat expansion.

Standard 1018 Screw Cover Head

1018 Series screw cover heads are Factory Mutual rated
 Per: NEC - Class 1, Division 1, Groups A, B, C and D
 - Class2, Division 1, Groups E, F, and G
 NEMA: - NEMA 4, Weather-proof - Indoor/Outdoor

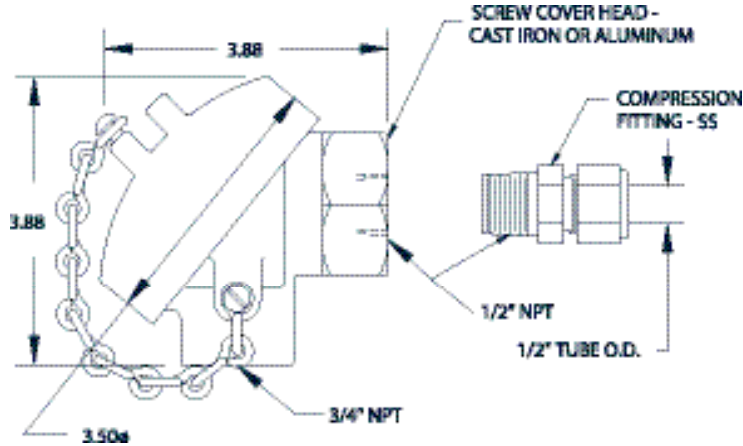

Optional Spring Loaded Cover Plate

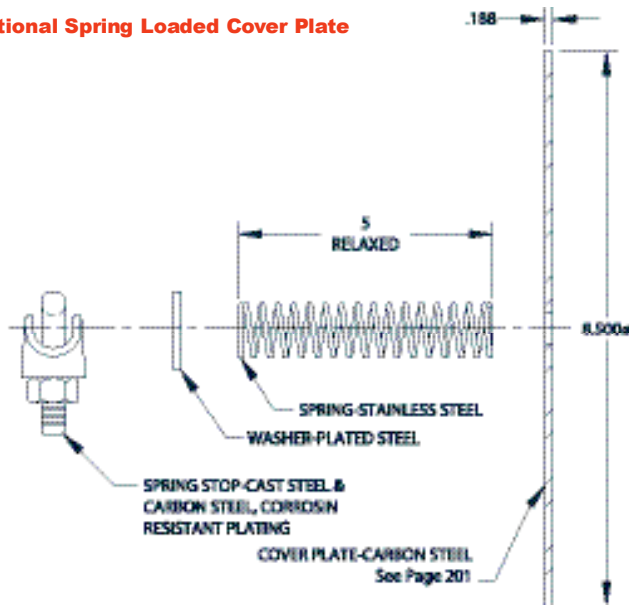

Standard Retaining Clip

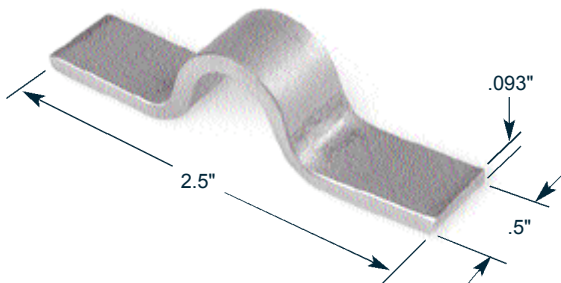

"Tube Temp" Weld Installation Details

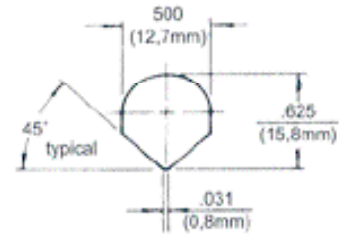
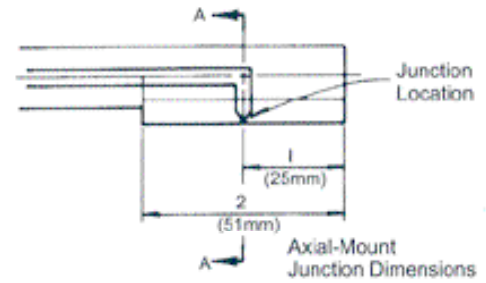
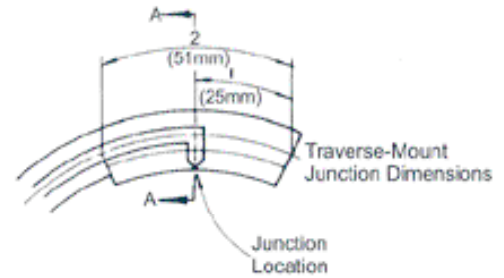

Section A-A: Typical shape full length of 2" (51mm) long "vee" pad

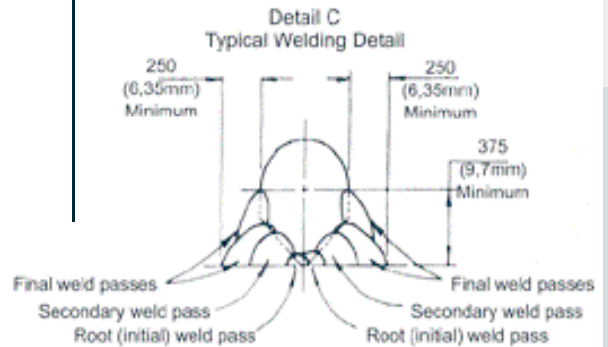

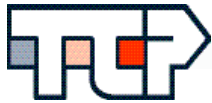

Thermo-Couple Products Co.

“TUBE TEMP”

Choosing a “Tube Temp” Thermocouple to Suit Your Application

Designing and fitting “Tube Temp” thermocouples for your new or existing heater is simplified with TCP’s wide selection of standard, pre-formed configurations. Due to the rigid construction of these rugged thermocouples, TCP highly recommends the use of preformed configurations which arrive at your site ready to install, thus eliminating difficult and tedious field forming operations which could adversely affect the integrity and service life of the assembly. While the configurations shown will apply to the majority of installations requirements, often special pre-forming may be required. TCP is experienced in designing custom preforms for the most intricate of installations, whether you require a 3 foot or 40 foot reach to your heater tube. Choosing the proper configuration can often be difficult and TCP has found the most commonly asked questions can be answered by the following information

Where Should The Junction Be Placed?

Location of the thermocouple junction is of prime importance and should place the measuring junction at the most critical temperature point on the heater tube. The thermocouple configuration chosen should permit all or most of the thermocouple to lie in the “shadow” of the pipe where temperature and atmospheric conditions are less extreme, allowing only the knife-edge junction to be exposed to the actual flame temperatures.

What Sheath Material Should Be Used?

Typically 446 is limited to 2100°F (1149°C) maximum service temperature and should be considered where high sulfur content of the heater fuel is a factor. Many installations utilizing lower sulfur content fuels and higher flame temperatures will dictate the use of 310SS which is generally serviceable up to 2100°F (1149°C) or Hastelloy X which is used up to 2200°F (1205°C).

What Configuration is Best Suited for My Application?

The location of your measurement point and its’ corresponding heater tube to the heater wall and external structure affect which configuration to choose from the examples on the preceding pages.

1. The simpler shapes, such as 1810, 1820, 1820C and 1830L or 1830R series, allow the thermocouple to penetrate the wall in line with the measurement point, placing the assembly transversely to the pipe axis.
2. Other designs such as 1800V, 1800L or 1800R series permit the measurement to be placed at the desired position while requiring the wall penetration to be more conveniently located due to external structural obstacles. These assemblies have axial oriented junctions; however, the 1820L and R series may be reconfigured for these conditions.
3. In general, the 1800, 1820L or 1820R are intended for end wall penetration with horizontal tubes and floor or ceiling penetration with vertical tubes. The wrap around of the knife-edge junction facilitates the protective placement of the usually longer than normal thermocouple length in the protective “shadow” of the pipe. These assemblies are particularly suitable for use where the heater tubes are subject to excessive axial movements.
4. In the event our standard configurations do not lend themselves to your application, TCP can easily alter any standard configuration with offsets, expansion loops or extra bends to suit your specifications and drawings. Our experienced engineering staff stands ready to assist you with special designs.

Will I Need an Expansion Loop?

Expansion loops may be desirable to accommodate heater tube movements, especially in transverse mounted assemblies such as 1830L or 1830R series. In cases where the heater tube movement is not only axial, but may cause movement along the X, Y and Z axis, this feature becomes necessary to reduce stresses in the thermocouple sheath. Expansion loops are particularly desirable when the thermocouple is permanently mounted in a compression fitting at the heater outer wall surface.

How Do I Specify the Length of the Thermocouple?

Determining the length of your assembly is quite simple. The “A” dimension consists of only two components: 1.) Distance from the outside surface of the heater wall measured to the center of the heater tube on which the thermocouple will be attached, and 2.) The length of outside extension desired from the outer surface of the heater wall to the terminal head mounting fitting; TCP recommends a minimum of 6 inches (310 mm). Simply add these two measurements to determine the required thermocouple length, i.e.: “A” dimension.

How Do I Specify the Heater Tube Size?

All heater tube sizes should be specified by outside diameter (O.D.) in inches, whether the heater tube are manufactured from tubing or pipe. This simply means, for example, 5 inch tube is 5 inches O.D., whereas 5 inch pipe is 5-9/16 inch O.D.

What are Spring Loaded Cover Plates Used For?

Spring loaded cover plates find use when it becomes desirable to allow the thermocouple to float within the heater wall penetration sleeve. Only about 10% of “Tube Temp” orders request spring loaded cover plates. The spring loading allows the entire thermocouple to slide in and out of the sleeve and still allow the cover plate to maintain firm contact with the outer face of the sleeve. TCP cover plates permit wall penetration sleeves up to 4” pipe size.

What are Thermocouples Requiring “Spring Loaded Plates” Measured Differently?

When cover plates are specified, TCP finds a longer extension length between the terminal head and the outer surface of the heater wall is necessary. Therefore, to eliminate calculation problems, we request the “A” dimension be measured from the outer surface of the heater wall to the center of the heater tube to which the thermocouple will be attached. TCP will then provide an additional 10 inches of thermocouple as part of the S-809 option, thus eliminating the overall length calculation normally required. See page 152 for an example of a typical “Tube Temp” thermocouple with a S-809 spring loaded cover plate.

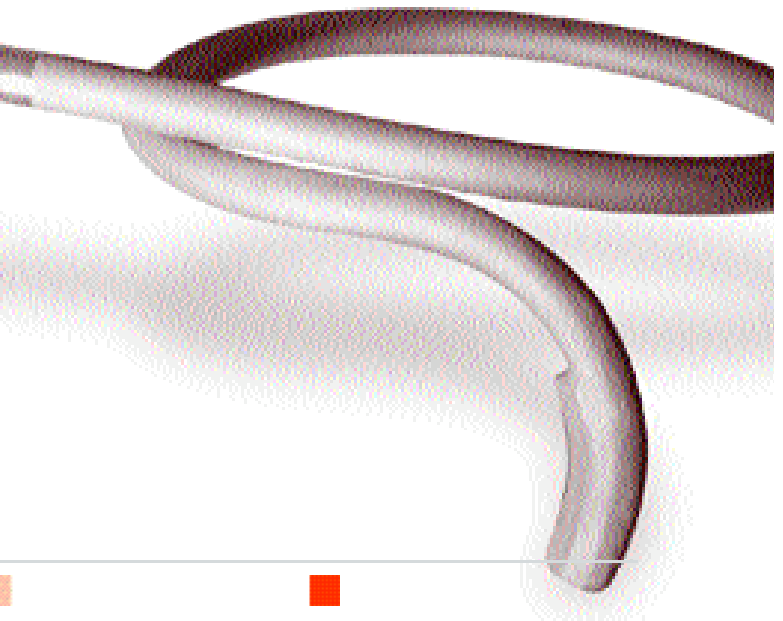

“TUBE TEMP”

Series 1800

- Patented “Knife-Edge” Thermojunction
- More Accurate than Pad Type Thermocouple
- Best Value for Accuracy and Longevity
- Retaining Clip Furnished, Clip Material Matches Sheath Material

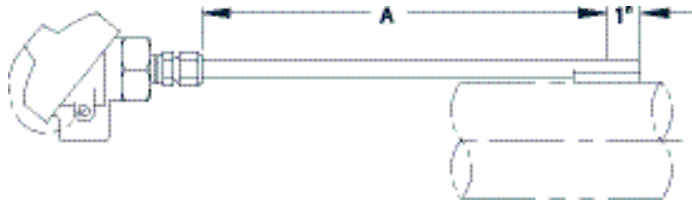

Enter a selection for each item, please fax your inquiry to TCP.

Example: 1800 - - - - - - -

1800 - - - - - - -

CODE	WIRE CALIBRATION
E	Chromel/Constantan
J	Iron/Constantan
K	Chromel/Alumel
EE	Duplex Chromel/Constantan
JJ	Duplex Iron/Constantan
KK	Duplex Chromel/Alumel
Consult factory for other calibrations	
Type K is standard	

CODE LENGTH "A"
Specify "A" dimension in inches (above). See page 152 for "A" dimension if spring loaded cover plate is needed.

CODE	JUNCTION STYLE
G	Grounded Junction
U	Ungrounded Junction
Grounded Junction is standard	

CODE	OTHER PERTINENT DATA
0	NONE
999	Special Consult Factory

CODE	SPRING LOADED COVER PLATE
0	None
S809	Spring Loaded
None is Standard	

CODE	HEAD
0	None
CI	Cast Iron
AL	Aluminum
Cast Iron is standard	

CODE	SHEATH MATERIAL
310	310 Stainless Steel
446	446 Stainless Steel
HAX	Hastelloy X
446SS is standard	
Hastelloy material has a thinner wall thickness.	

Metric Orders Welcome

Place an **mm** in the appropriate selection box:

100 mm

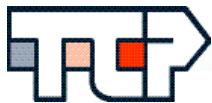

Thermo-Couple Products Co.

“TUBE TEMP”

Series 1800L

- Patented “Knife-Edge” Thermojunction
- More Accurate than Pad Type Thermocouple
- Right Angle Bend which Turns Left for Ease of Installation
- Best Value for Accuracy and Longevity
- Retaining Clip Furnished, Clip Material Matches Sheath Material

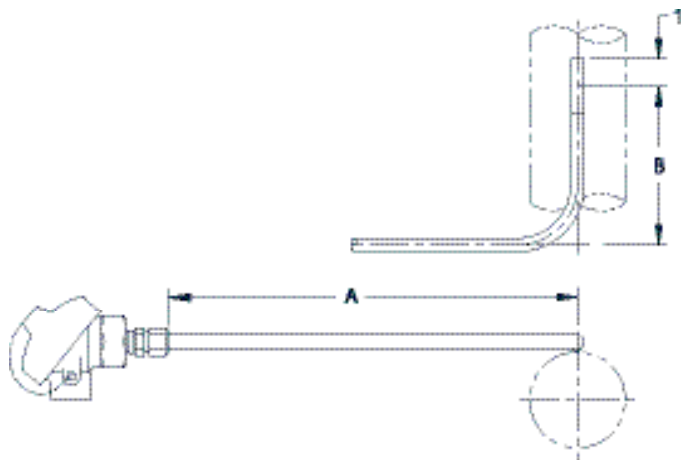

Enter a selection for each item, please fax your inquiry to TCP.

Example: 1800L - - - - - - - -

1800L - - - - - - - -

CODE	WIRE CALIBRATION
E	Chromel/Constantan
J	Iron/Constantan
K	Chromel/Alumel
EE	Duplex Chromel/Constantan
JJ	Duplex Iron/Constantan
KK	Duplex Chromel/Alumel
Consult factory for other calibrations	
Type K is standard	

COLD LENGTH “A”
Specify “A” dimension in inches (above). See page 152 for “A” dimension if spring loaded cover plate is needed.

HOT LENGTH “B”
Specify “B” dimension in inches.

CODE	JUNCTION STYLE
G	Grounded Junction
U	Ungrounded Junction
Grounded Junction is standard	

CODE	OTHER PERTINENT DATA
0	NONE
999	Special Consult Factory

CODE	SPRING LOADED COVER PLATE
0	None
S809	Spring Loaded
None is Standard	

CODE	HEAD
0	None
CI	Cast Iron
AL	Aluminum
Cast Iron is standard	

CODE	SHEATH MATERIAL
310	310 Stainless Steel
446	446 Stainless Steel
HAX	Hastelloy X
446SS is standard	
Hastelloy material has a thinner wall thickness.	

	Metric Orders Welcome
	Place an mm in the appropriate selection box: <input type="text" value="100 mm"/>

“TUBE TEMP”

Series 1800R

- Patented “Knife-Edge” Thermojunction
- More Accurate than Pad Type Thermocouple
- Right Angle Bend which Turns Right for Ease of Installation
- Best Value for Accuracy and Longevity
- Retaining Clip Furnished, Clip Material Matches Sheath Material

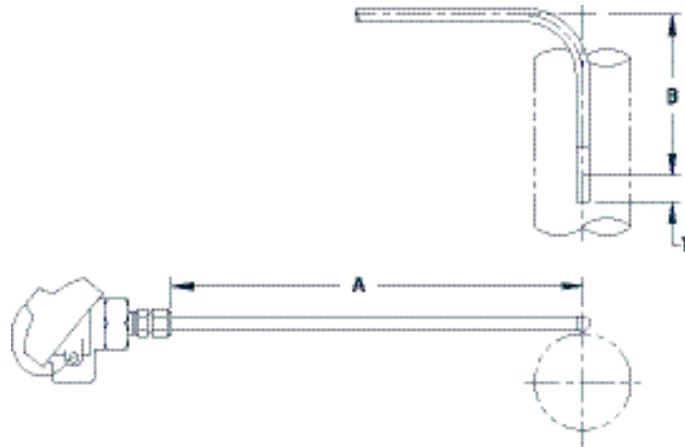

Enter a selection for each item, please fax your inquiry to TCP.

Example: 1800R - - - - - - - -

1800R - - - - - - - -

CODE	WIRE CALIBRATION
E	Chromel/Constantan
J	Iron/Constantan
K	Chromel/Alumel
EE	Duplex Chromel/Constantan
JJ	Duplex Iron/Constantan
KK	Duplex Chromel/Alumel
Consult factory for other calibrations	
Type K is standard	

COLD LENGTH “A”
Specify “A” dimension in inches (above). See page 152 for “A” dimension if spring loaded cover plate is needed.

HOT LENGTH “B”
Specify “B” dimension in inches.

CODE	JUNCTION STYLE
G	Grounded Junction
U	Ungrounded Junction
Grounded Junction is standard	

CODE	OTHER PERTINENT DATA
0	NONE
999	Special Consult Factory

CODE	SPRING LOADED COVER PLATE
0	None
S809	Spring Loaded
None is Standard	

CODE	HEAD
0	None
CI	Cast Iron
AL	Aluminum
Cast Iron is standard	

CODE	SHEATH MATERIAL
310	310 Stainless Steel
446	446 Stainless Steel
HAX	Hastelloy X
446SS is standard	
Hastelloy material has a thinner wall thickness.	

! Metric Orders Welcome

Place an **mm** in the appropriate selection box:



Thermo-Couple Products Co.

“TUBE TEMP”

Series 1800V

- Patented “Knife-Edge” Thermojunction
- More Accurate than Pad Type Thermocouple
- Different Plane of Mounting between Inlet and Heater Tube
- Best Value for Accuracy and Longevity
- Retaining Clip Furnished, Clip Material Matches Sheath Material

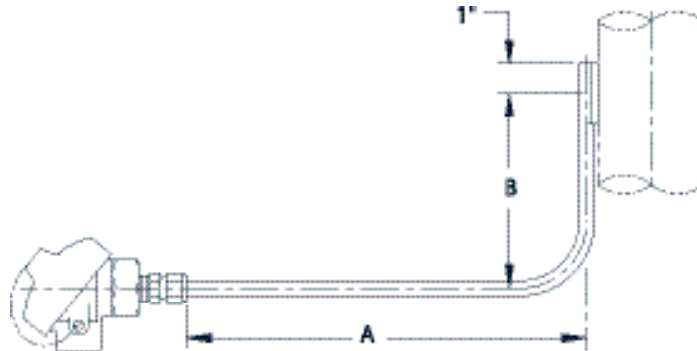

Tube Temps

Enter a selection for each item, please fax your inquiry to TCP.

Example: 1800V - - - - - - - -

1800V - - - - - - - -

CODE	WIRE CALIBRATION
E	Chromel/Constantan
J	Iron/Constantan
K	Chromel/Alumel
EE	Duplex Chromel/Constantan
JJ	Duplex Iron/Constantan
KK	Duplex Chromel/Alumel
Consult factory for other calibrations	
Type K is standard	

COLD LENGTH “A”
Specify “A” dimension in inches (above). See page 152 for “A” dimension if spring loaded cover plate is needed.

HOT LENGTH “B”
Specify “B” dimension in inches.

CODE	JUNCTION STYLE
G	Grounded Junction
U	Ungrounded Junction
Grounded Junction is standard	

CODE	OTHER PERTINENT DATA
0	NONE
999	Special Consult Factory

CODE	SPRING LOADED COVER PLATE
0	None
S809	Spring Loaded
None is Standard	

CODE	HEAD
0	None
CI	Cast Iron
AL	Aluminum
Cast Iron is standard	

CODE	SHEATH MATERIAL
310	310 Stainless Steel
446	446 Stainless Steel
HAX	Hastelloy X
446SS is standard	
Hastelloy material has a thinner wall thickness.	

Metric Orders Welcome

Place an **mm** in the appropriate selection box:

100 mm

“TUBE TEMP”

Series 1810

- Patented “Knife-Edge” Thermojunction
- More Accurate than Pad Type Thermocouple
- For Transverse Tangent Mounting Where Tube Movements are Minimal
- Best Value for Accuracy and Longevity
- Retaining Clip Furnished, Clip Material Matches Sheath Material

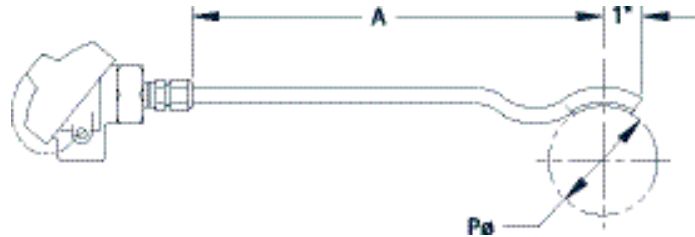

Enter a selection for each item, please fax your inquiry to TCP.

Example: 1810 - **K** - 36 - 4.5 - **G** - 446 - **CI** - 0 - 0

1810 - - - - - - - -

CODE	WIRE CALIBRATION
E	Chromel/Constantan
J	Iron/Constantan
K	Chromel/Alumel
EE	Duplex Chromel/Constantan
JJ	Duplex Iron/Constantan
KK	Duplex Chromel/Alumel
Consult factory for other calibrations	
Type K is standard	

LENGTH “A”
Specify “A” dimension in inches (above). See page 152 for “A” dimension if spring loaded cover plate is needed.

HEATER TUBE DIAMETER “P”
Specify “P” dimension in inches. Actual tube outside diameter is required. (3.5" min.)

CODE	OTHER PERTINENT DATA
0	NONE
999	Special Consult Factory

CODE	SPRING LOADED COVER PLATE
0	None
S809	Spring Loaded
None is Standard	

CODE	HEAD
0	None
CI	Cast Iron
AL	Aluminum
Cast Iron is standard	

CODE	SHEATH MATERIAL
310	310 Stainless Steel
446	446 Stainless Steel
HAX	Hastelloy X
446SS is standard	
Hastelloy material has a thinner wall thickness.	

CODE	JUNCTION STYLE
G	Grounded Junction
U	Ungrounded Junction
Grounded Junction is standard	

Metric Orders Welcome

Place an **mm** in the appropriate selection box:

100 mm

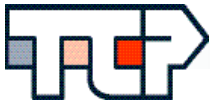

Thermo-Couple Products Co.

“TUBE TEMP”

Series 1820

- Patented “Knife-Edge” Thermojunction
- More Accurate than Pad Type Thermocouple
- Most Commonly Used Design without Expansion Loop
- Best Value for Accuracy and Longevity
- Wrap Around Angle 90° “W”
- Retaining Clip Furnished, Clip Material Matches Sheath Material

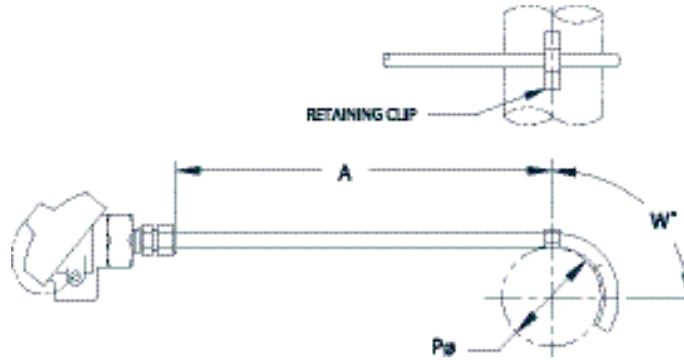

Tube Temps

Enter a selection for each item, please fax your inquiry to TCP.

Example: 1820 - **K** - **36** - **4.5** - **90** - **G** - **446** - **CI** - **0** - **0**

1820 - - - - - - - - -

CODE	WIRE CALIBRATION
E	Chromel/Constantan
J	Iron/Constantan
K	Chromel/Alumel
EE	Duplex Chromel/Constantan
JJ	Duplex Iron/Constantan
KK	Duplex Chromel/Alumel
Consult factory for other calibrations	
Type K is standard	

LENGTH “A”
Specify “A” dimension in inches (above). See page 152 for “A” dimension if spring loaded cover plate is needed.

HEATER TUBE DIAMETER “P”
Specify “P” dimension in inches. Actual tube outside diameter is required. (6” min.)

WRAP A ROUND ANGLE “W”
90 90° (Standard)
Specify other angles in degrees.

CODE	JUNCTION STYLE
G	Grounded Junction
U	Ungrounded Junction
Grounded Junction is standard	

CODE	OTHER PERTINENT DATA
0	NONE
999	Special Consult Factory

CODE	SPRING LOADED COVER PLATE
0	None
S809	Spring Loaded
None is Standard	

CODE	HEAD
0	None
CI	Cast Iron
AL	Aluminum
Cast Iron is standard	

CODE	SHEATH MATERIAL
310	310 Stainless Steel
446	446 Stainless Steel
HAX	Hastelloy X
446SS is standard	
Hastelloy material has a thinner wall thickness.	

Metric Orders Welcome

Place an **mm** in the appropriate selection box:

100 mm

“TUBE TEMP”

Series 1820L

- Patented “Knife-Edge” Thermojunction
- More Accurate than Pad Type Thermocouple
- Best Value for Accuracy and Longevity
- Wrap Around Angle 90° “W”
- Retaining Clip Furnished, Clip Material Matches Sheath Material
- For Thru-Floor or Roof Penetration where Thermocouple Can Move with Tube

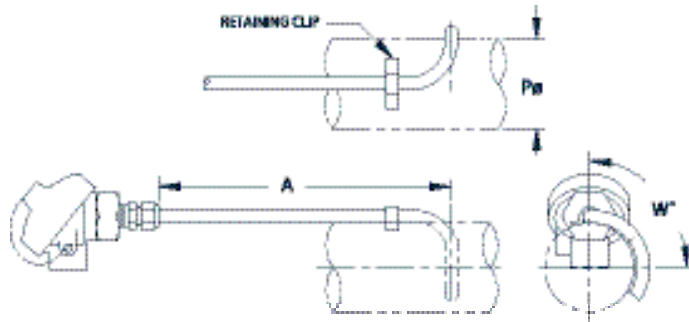

Enter a selection for each item, please fax your inquiry to TCP.

1820L - - - - - - - - -

1820L - - - - - - - - -

CODE	WIRE CALIBRATION
E	Chromel/Constantan
J	Iron/Constantan
K	Chromel/Alumel
EE	Duplex Chromel/Constantan
JJ	Duplex Iron/Constantan
KK	Duplex Chromel/Alumel
Consult factory for other calibrations	
Type K is standard	

LENGTH “A”
Specify “A” dimension in inches (above). See page 152 for “A” dimension if spring loaded cover plate is needed.

HEATER TUBE DIAMETER “P”
Specify “P” dimension in inches. Actual tube outside diameter is required. (6" min.)

WRAP AROUND ANGLE “W”
90 90° (Standard)
Specify other angles in degrees.

CODE	OTHER PERTINENT DATA
0	NONE
999	Special Consult Factory

CODE	SPRING LOADED COVER PLATE
0	None
S809	Spring Loaded
None is Standard	

CODE	HEAD
0	None
CI	Cast Iron
AL	Aluminum
Cast Iron is standard	

CODE	SHEATH MATERIAL
310	310 Stainless Steel
446	446 Stainless Steel
HAX	Hastelloy X
446SS is standard	
Hastelloy material has a thinner wall thickness.	

CODE	JUNCTION STYLE
G	Grounded Junction
U	Ungrounded Junction
Grounded Junction is standard	

Metric Orders Welcome

Place an **mm** in the appropriate selection box:

100 mm

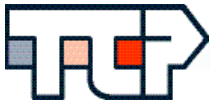

Thermo-Couple Products Co.

“TUBE TEMP”

Series 1820R

- Patented “Knife-Edge” Thermojunction
- More Accurate than Pad Type Thermocouple
- Best Value for Accuracy and Longevity
- Wrap Around Angle 90° “W”
- Retaining Clip Furnished, Clip Material Matches Sheath Material
- For Thru-Floor or Roof Penetration where Thermocouple Can Move with Tube

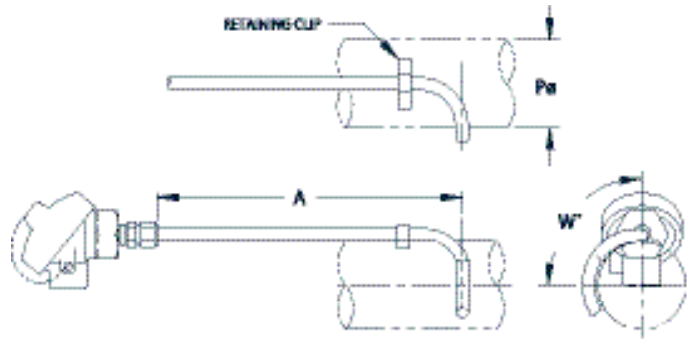

Tube Temps

Enter a selection for each item, please fax your inquiry to TCP.

Example: 1820R - - - - - - - - -

1820R - - - - - - - - -

CODE	WIRE CALIBRATION
E	Chromel/Constantan
J	Iron/Constantan
K	Chromel/Alumel
EE	Duplex Chromel/Constantan
JJ	Duplex Iron/Constantan
KK	Duplex Chromel/Alumel
Consult factory for other calibrations	
Type K is standard	

LENGTH “A”
Specify “A” dimension in inches (above). See page 152 for “A” dimension if spring loaded cover plate is needed.

HEATER TUBE DIAMETER “P”
Specify “P” dimension in inches. Actual tube outside diameter is required. (6” min.)

WRAP AROUND ANGLE “W”
90 90° (Standard)
Specify other angles in degrees.

CODE	JUNCTION STYLE
G	Grounded Junction
U	Ungrounded Junction
Grounded Junction is standard	

CODE	OTHER PERTINENT DATA
0	NONE
999	Special Consult Factory

CODE	SPRING LOADED COVER PLATE
0	None
S809	Spring Loaded
None is Standard	

CODE	HEAD
0	None
CI	Cast Iron
AL	Aluminum
Cast Iron is standard	

CODE	SHEATH MATERIAL
310	310 Stainless Steel
446	446 Stainless Steel
HAX	Hastelloy X
446SS is standard	
Hastelloy material has a thinner wall thickness.	

Metric Orders Welcome

Place an **mm** in the appropriate selection box:

100 mm

“TUBE TEMP”

Series 1820C

- Patented “Knife-Edge” Thermojunction
- More Accurate than Pad Type Thermocouple
- Best Value for Accuracy and Longevity
- Wrap Around Angle 90° “W”
- Retaining Clip Furnished, Clip Material Matches Sheath Material

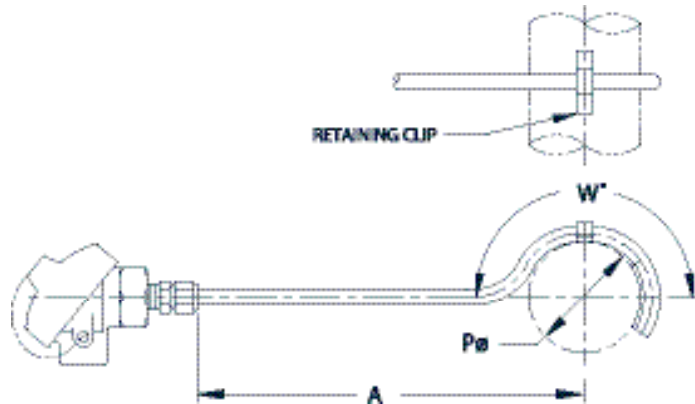

Enter a selection for each item, please fax your inquiry to TCP.

Example: 1820C - K - 36 - 6.625 - 180 - G - 446 - CI - 0 - 0

1820C - - - - - - - - -

CODE	WIRE CALIBRATION
E	Chromel/Constantan
J	Iron/Constantan
K	Chromel/Alumel
EE	Duplex Chromel/Constantan
JJ	Duplex Iron/Constantan
KK	Duplex Chromel/Alumel
Consult factory for other calibrations	
Type K is standard	

LENGTH “A”
Specify “A” dimension in inches (above). See page 152 for “A” dimension if spring loaded cover plate is needed.

HEATER TUBE DIAMETER “P”
Specify “P” dimension in inches. Actual tube outside diameter is required. (3.5” min.)

WRAP AROUND ANGLE “W”
180 180° (Standard)
Specify other angles in degrees.

CODE	OTHER PERTINENT DATA
0	NONE
999	Special Consult Factory

CODE	SPRING LOADED COVER PLATE
0	None
S809	Spring Loaded
None is Standard	

CODE	HEAD
0	None
CI	Cast Iron
AL	Aluminum
Cast Iron is standard	

CODE	SHEATH MATERIAL
310	310 Stainless Steel
446	446 Stainless Steel
HAX	Hastelloy X
446SS is standard	
Hastelloy material has a thinner wall thickness.	

CODE	JUNCTION STYLE
G	Grounded Junction
U	Ungrounded Junction
Grounded Junction is standard	

Metric Orders Welcome

Place an **mm** in the appropriate selection box:

100 mm

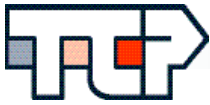

Thermo-Couple Products Co.

“TUBE TEMP”

Series 1830L

- Patented “Knife-Edge” Thermojunction
 - More Accurate than Pad Type Thermocouple
 - Most Commonly Used Design with Expansion Loop
 - Ideal for Applications where Tube Movement is Greater than 3"
 - Best Value for Accuracy and Longevity
 - Wrap Around Angle 90° “W”
- Retaining Clip Furnished, Clip Material Matches Sheath Material

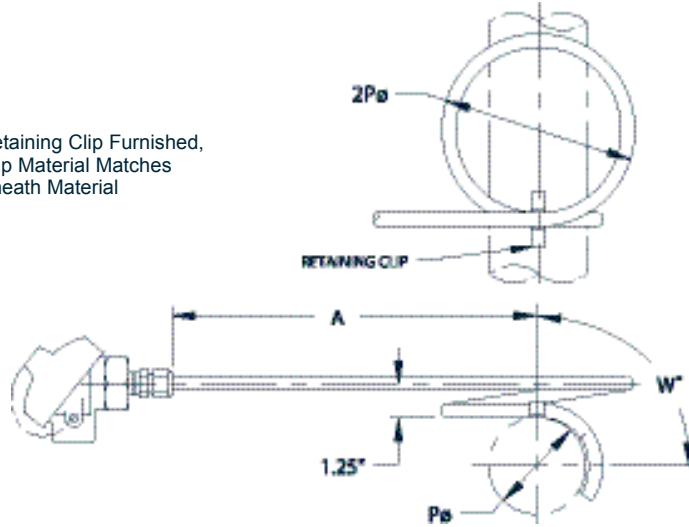

Tube Temps

Enter a selection for each item, please fax your inquiry to TCR.

Example: 1830L - - - - - - - - -

1830L - - - - - - - - -

CODE	WIRE CALIBRATION
E	Chromel/Constantan
J	Iron/Constantan
K	Chromel/Alumel
EE	Duplex Chromel/Constantan
JJ	Duplex Iron/Constantan
KK	Duplex Chromel/Alumel
Consult factory for other calibrations	
Type K is standard	

LENGTH “A”
Specify “A” dimension in inches (above). See page 152 for “A” dimension if spring loaded cover plate is needed.

HEATER TUBE DIAMETER “P”
Specify “P” dimension in inches. Actual tube outside diameter is required. (3.5" min.)

WRAP A ROUND ANGLE “W”
90 90° (Standard)
Specify other angles in degrees.

CODE	JUNCTION STYLE
G	Grounded Junction
U	Ungrounded Junction
Grounded Junction is standard	

CODE	OTHER PERTINENT DATA
0	NONE
999	Special Consult Factory

CODE	SPRING LOADED COVER PLATE
0	None
S809	Spring Loaded
None is Standard	

CODE	HEAD
0	None
CI	Cast Iron
AL	Aluminum
Cast Iron is standard	

CODE	SHEATH MATERIAL
310	310 Stainless Steel
446	446 Stainless Steel
HAX	Hastelloy X
446SS is standard	
Hastelloy material has a thinner wall thickness.	

Metric Orders Welcome

Place an **mm** in the appropriate selection box:

100 mm

“TUBE TEMP”

Series 1830R

- Patented “Knife-Edge” Thermojunction
- More Accurate than Pad Type Thermocouple
- Most Commonly Used Design with Expansion Loop
- Ideal for Applications where Tube Movement is Greater than 3"
- Best Value for Accuracy and Longevity
- Wrap Around Angle 90° “W”
- Retaining Clip Furnished, Clip Material Matches Sheath Material

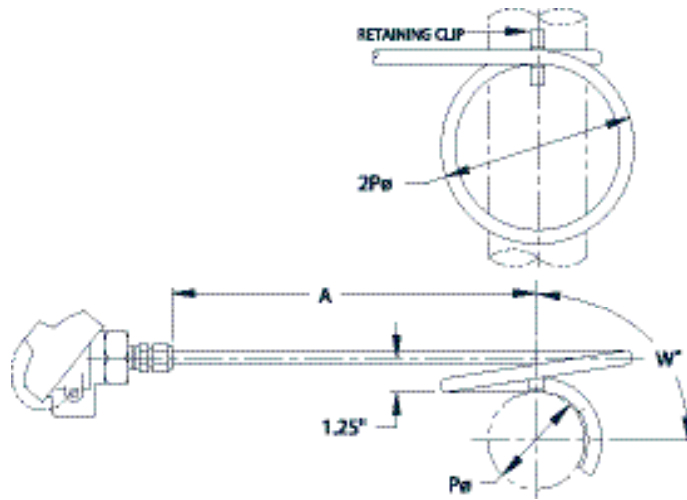

Enter a selection for each item, please fax your inquiry to TCP.

Example: 1830R - K - 36 - 6.625 - 90 - G - 446 - CI - 0 - 0

1830R - - - - - - - - - -

CODE	WIRE CALIBRATION
E	Chromel/Constantan
J	Iron/Constantan
K	Chromel/Alumel
EE	Duplex Chromel/Constantan
JJ	Duplex Iron/Constantan
KK	Duplex Chromel/Alumel
Consult factory for other calibrations	
Type K is standard	

LENGTH “A”
Specify “A” dimension in inches (above). See page 152 for “A” dimension if spring loaded cover plate is needed.

HEATER TUBE DIAMETER “P”
Specify “P” dimension in inches. Actual tube outside diameter is required. (3.5" min.)

WRAP AROUND ANGLE “W”
90 90° (Standard)
Specify other angles in degrees.

CODE	OTHER PERTINENT DATA
0	NONE
999	Special Consult Factory

CODE	SPRING LOADED COVER PLATE
0	None
S809	Spring Loaded
None is Standard	

CODE	HEAD
0	None
CI	Cast Iron
AL	Aluminum
Cast Iron is standard	

CODE	SHEATH MATERIAL
310	310 Stainless Steel
446	446 Stainless Steel
HAX	Hastelloy X
446SS is standard	
Hastelloy material has a thinner wall thickness.	

CODE	JUNCTION STYLE
G	Grounded Junction
U	Ungrounded Junction
Grounded Junction is standard	

Metric Orders Welcome

Place an **mm** in the appropriate selection box:

100 mm

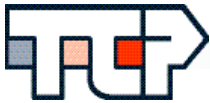

Thermo-Couple Products Co.

“TUBE TEMP” INSTALLATION DETAILS

TYPE 1 - FOR INSTALLATIONS INVOLVING TUBE WALL TEMPERATURE MEASUREMENT

EXPANSION MOVEMENT ALLOWANCE:

- SIZE A - Minimal, dependent on Feed-Term Sleeve I.D.
- SIZE B - Minimal, dependent on Feed-Term Sleeve I.D.
- SIZE C - Infinite, dependent on Tension Spring characteristics.

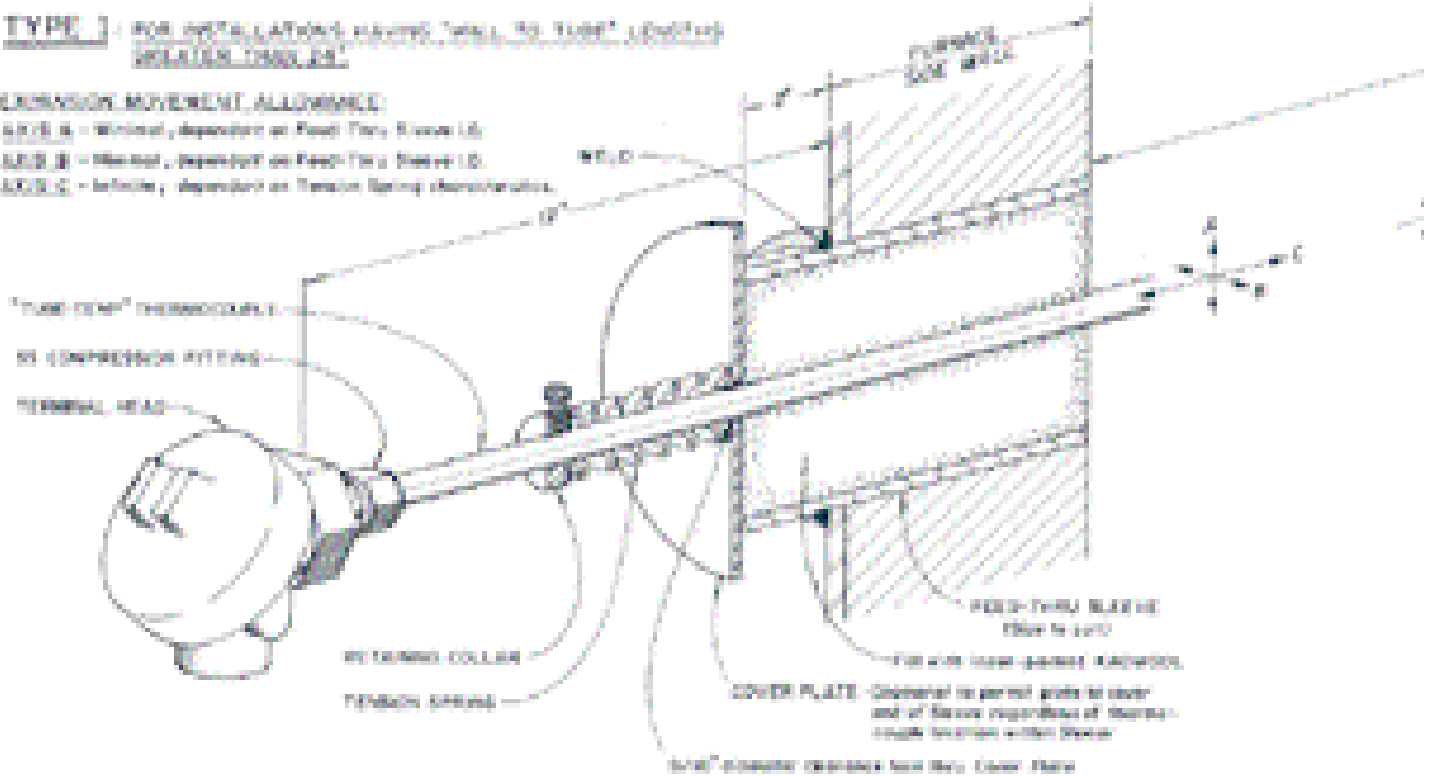

“TUBE TEMP”

Part Identification

1. Spring Stop
2. Washer
3. Spring
4. Cover Plate

Spring Loaded Cover Plate Detail:
“Tube Temp” Thermocouple

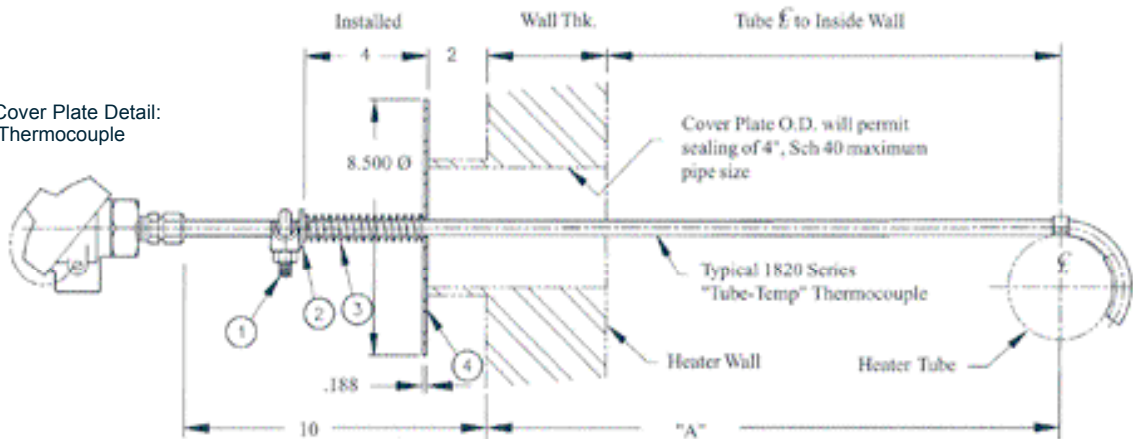

Note:

When the option S809, a spring loaded convert plate, has been selected, then the “A” dimension is the distance from the outside heater wall to the center of the heater tube. The distance from the heater wall to the fitting on the Thermocouple head is always 10”. This allows room for the spring loaded cover plate assembly.

To order, specify: “S809” for spring loaded,
Example: Typical Part Number for the assembly shown above;

1820-K-36-4.5-90°-G-446-CI-S809-0

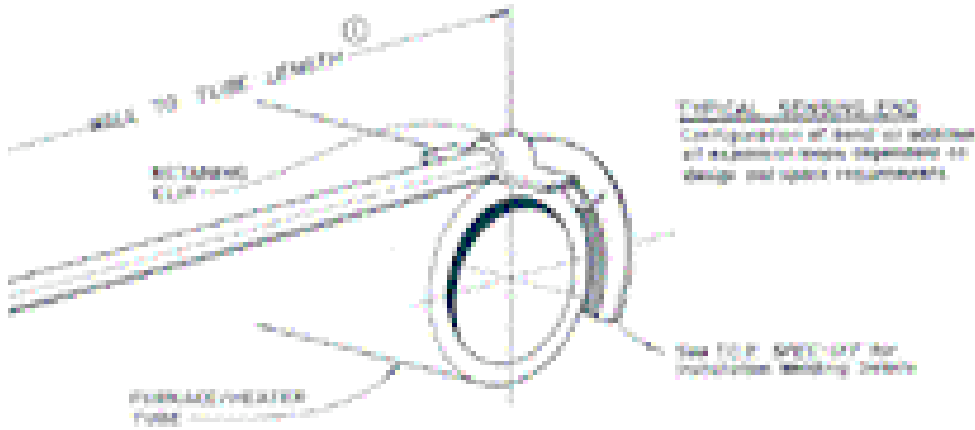

"Tube-Temp" Thermocouple
 U.S. Patent Numbers
 3,874,239 , 3,939,554 - 4,043,200
 Canada Patent No. 1,012,258 - 1,016,666
 Great Britain 1,478,919
 Japan 1,043,379 - 1,070,744

TYPE 3: FOR INSTALLATIONS HAVING "WALL TO TUBE" LENGTHS LESS THAN 60" ①

EXPANSION MOVEMENT ALLOWANCE:
 AXIS A - Minimal
 AXIS B - Minimal
 AXIS C - Infinite

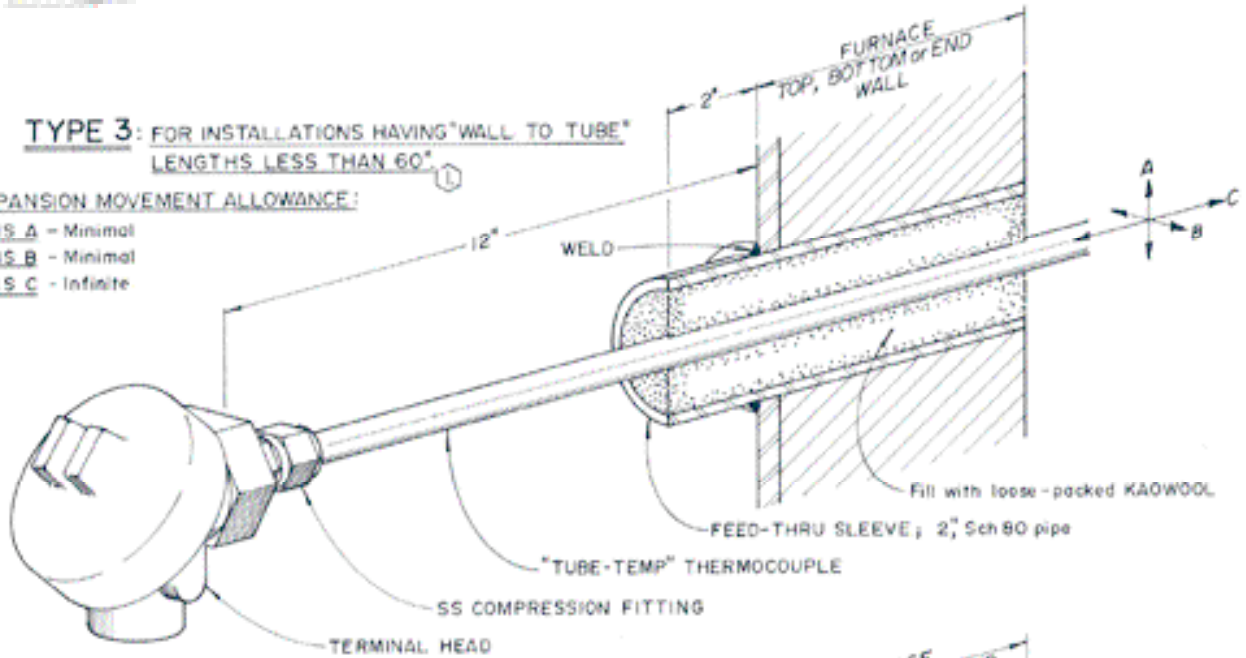

TYPE 4: FOR INSTALLATIONS HAVING "WALL TO TUBE" LENGTHS GREATER THAN 60" ①

EXPANSION MOVEMENT ALLOWANCE:
 AXIS A - None
 AXIS B - None
 AXIS C - Infinite

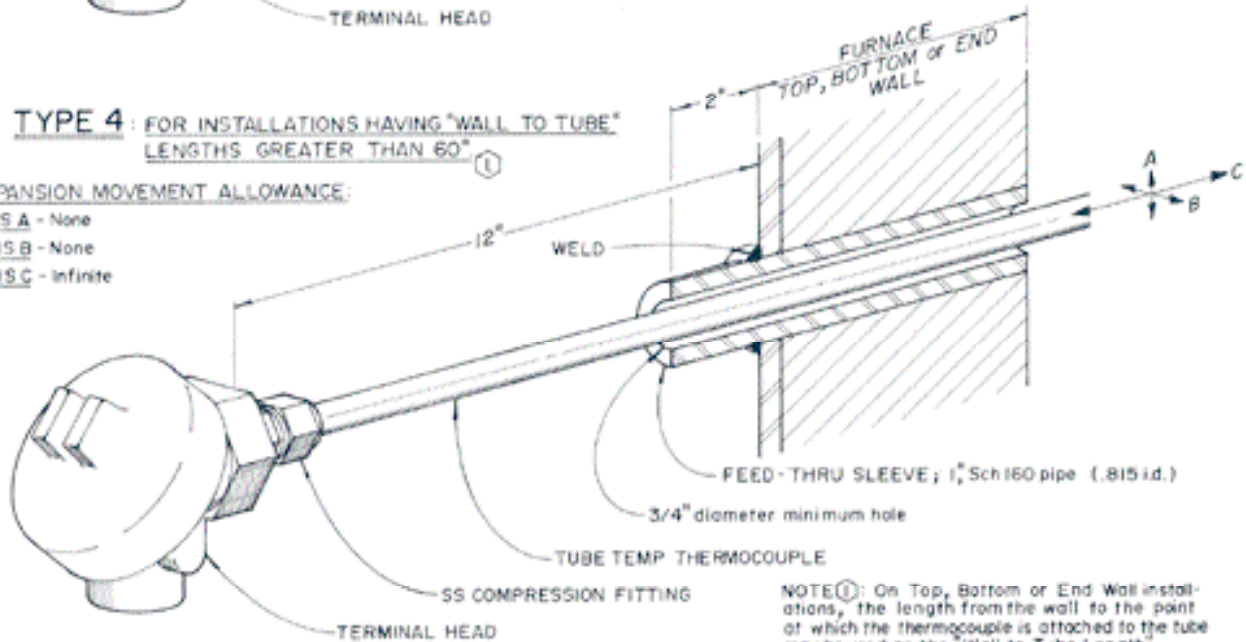

NOTE ①: On Top, Bottom or End Wall installations, the length from the wall to the point at which the thermocouple is attached to the tube may be used as the "Wall to Tube Length".

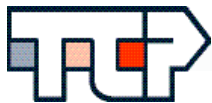

Thermo-Couple Products Co.

PAD TYPE

Series 1700

- Pad Type 1700 is a Low Cost Alternative to "Tube Temp" Thermocouple (See pages 141 - 151)
- Pad is Slotted for Higher Accuracy
- Used Where Severe Service Atmospheric Conditions are Not a Major Concern
- Suitable for Tight Space Limitations
- Can be Field Formed

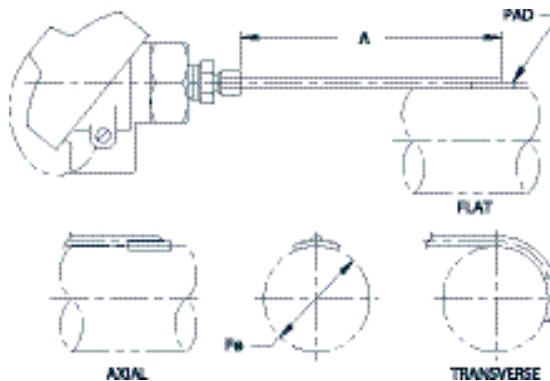

Tube Temps

Enter a selection for each item, please fax your inquiry to TCP.

Example: 1700 - - - - - - - - -

1700 - - - - - - - - -

CODE	WIRE CALIBRATION
E	Chromel/Constantan
J	Iron/Constantan
K	Chromel/Alumel
T	Copper/Constantan
EE	Duplex Chromel/Constantan
JJ	Duplex Iron/Constantan
KK	Duplex Chromel/Alumel
TT	Duplex Copper/Constantan
Type K is standard	

CODE	SHEATH DIAMETER
E	.187"
F	.250"

LENGTH "A"
Specify "A" dimension in inches.

CODE	JUNCTION STYLE
G	Grounded Junction
U	Ungrounded Junction
Grounded Junction is standard	

CODE	SHIELD
0	None
1	Straight Shield
2	Curved Shield

CODE	TERMINATIONS
10	111 Series Connector
18	18" of Lead Wire
40	Stripped Leads
AL	Aluminum Head
CI	Cast Iron Head

PIPE DIAMETER "P"
Specify "P" dimension in inches.

CODE	MOUNTING
A	Axial
T	Transverse
F	Flat
Flat is standard	

CODE	SHEATH MATERIAL
304	304 Stainless Steel
310	310 Stainless Steel
316	316 Stainless Steel

Metric Orders Welcome

Place an **mm** in the appropriate selection box:

100 mm

Ordering Information	
1.	Retaining clip can be furnished (customer to specify), clip material matches sheath material.
2.	1018 Series screw cover heads are Factory Mutual rated Per: NEC - Class 1, Division 1, Groups A, B, C and D - Class 2, Division 1, Groups E, F, and G NEMA - NEMA4, Weather-proof - Indoor/Outdoor

PAD TYPE

Series 1710

- Pad Type 1710 is a Lower Cost Alternative to “Tube Temp” Thermocouple (See pages 141 - 151)
- Thermocouple is Welded on Top of Pad
- Used Where Severe Service Atmospheric Conditions are Not a Major Concern
- Suitable for Tight Space Limitations
- Can be Field Formed

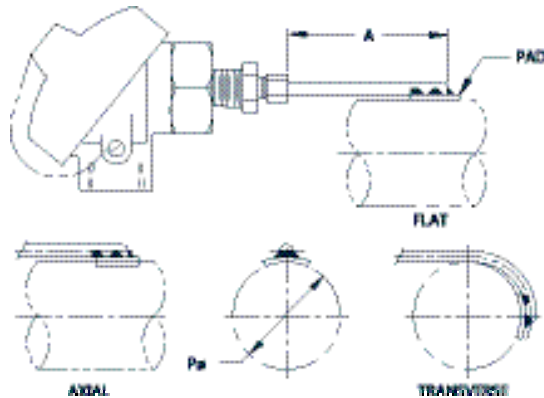

Enter a selection for each item, please fax your inquiry to TCP.

Example: 1710 - K - E - 36 - G - 304 - A - 3 - 10 - 0

1710 - - - - - - - - - -

CODE	WIRE CALIBRATION
E	Chromel/Constantan
J	Iron/Constantan
K	Chromel/Alumel
T	Copper/Constantan
EE	Duplex Chromel/Constantan
JJ	Duplex Iron/Constantan
KK	Duplex Chromel/Alumel
TT	Duplex Copper/Constantan
Type K is standard	

CODE	SHEATH DIAMETER
E	.187"
F	.250"

LENGTH "A"
Specify "A" dimension in inches.

CODE	JUNCTION STYLE
G	Grounded Junction
U	Ungrounded Junction
Grounded Junction is standard	

CODE	SHIELD
0	None
1	Straight Shield
2	Curved Shield

CODE	TERMINATIONS
10	111 Series Connector
18	18" of Lead Wire
40	Stripped Leads
AL	Aluminum Head
CI	Cast Iron Head

PIPE DIAMETER "P"
Specify "P" dimension in inches.

CODE	MOUNTING
A	Axial
T	Transverse
F	Flat
Flat is standard	

CODE	SHEATH MATERIAL
304	304 Stainless Steel
310	310 Stainless Steel
316	316 Stainless Steel

Ordering Information	
1.	Retaining clip can be furnished (customer to specify), clip material matches sheath material.
2.	1018 Series screw cover heads are Factory Mutual rated Per: NEC - Class 1, Division 1, Groups A, B, C and D - Class 2, Division 1, Groups E, F, and G NEMA - NEMA4, Weather-proof - Indoor/Outdoor

	Metric Orders Welcome
	Place an mm in the appropriate selection box: <input style="width: 50px;" type="text" value="100 mm"/>



Thermo-Couple Products Co.

PAD TYPE

Series 1720

- Pad Type 1720 is the Lowest Cost Alternative to "Tube Temp" Thermocouple (See pages 141 - 151)
- Commonly Referred to as "Tube Metal or Tube Skin Temperature Thermocouples"
- Used Where Maximum Service Temperature is 800°F
- 304SS Pad and Tube with 20 AWG Fiberglass Insulated Leadwire
- Suitable for Tight Space Limitations
- Can be Field Formed

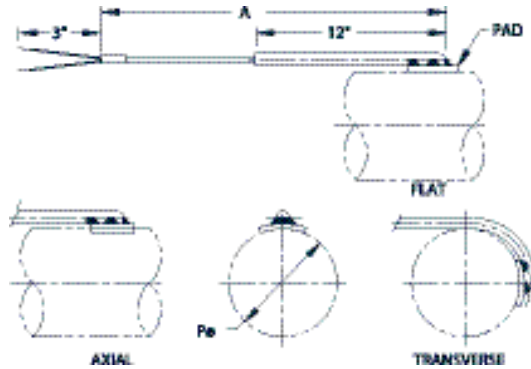

Tube Temps

Enter a selection for each item, please fax your inquiry to TCP.

Example: 1720 - - - - - - - - -

1720 - - - - - - - - -

CODE	WIRE CALIBRATION
E	Chromel/Constantan
J	Iron/Constantan
K	Chromel/Alumel
T	Copper/Constantan
EE	Duplex Chromel/Constantan
JJ	Duplex Iron/Constantan
KK	Duplex Chromel/Alumel
TT	Duplex Copper/Constantan

Type K is standard

CODE	SHEATH DIAMETER
E	.187"
F	.250"

LENGTH "A"
Specify "A" dimension in inches.

CODE	JUNCTION STYLE
G	Grounded Junction

CODE	SHIELD
0	None

CODE	TERMINATIONS
10	111 Series Connector
40	Stripped Leads

Consult factory for other terminations

PIPE DIAMETER "P"
Specify "P" dimension in inches.

CODE	MOUNTING
A	Axial
T	Transverse
F	Flat

Flat is standard

CODE	SHEATH MATERIAL
304	304 Stainless Steel

Metric Orders Welcome

Place an **mm** in the appropriate selection box:

Ordering Information

1. Retaining clip can be furnished (customer to specify), clip material matches sheath material.